

LOGIK MHF68



USER'S MANUAL

www.Tecnikchargers.com

MODEL NUMBER BREAKDOWN

MHF-BA3-64803-48/200

↓

TECHNOLOGY
(Multi High Frequency)

↓

CONTROL BOARD

↓

INPUT VOLTAGE/ PHASE
64803 (600/480Vac-3ph)

↓

OUTPUT VOLTAGE

↓

OUTPUT CURRENT

CABINET DIMENSIONS
(L x W x H in Inches)

A ▶ 19.88 x 14.06 x 27.24

B ▶ 19.88 x 17.40 x 35.47

MAXI ▶ 24.55 x 20.55 x 41.61

WARRANTY

- ▶ 5 Year Full Warranty
- ▶ 10 Year Power Warranty

 CEC Models Available

1. SAFETY INSTRUCTIONS AND WARNINGS

GENERAL

Battery chargers can cause injury or death, or damage to other equipment or property, if the user does not strictly observe all safety rules and take precautionary actions.

Safe practices must be learned through study and training before using this equipment.

Only qualified personnel should install, use, or service this battery charger.

SHOCK PREVENTION

Bare conductors, or terminals in the output circuit, or ungrounded, electrically-live equipments can fatally shock a person. To protect against shock, have competent electrician verify that the equipment is adequately grounded and learn what terminals and parts are electrically HOT.

The body's electrical resistance is decreased when wet, permitting dangerous current to flow through the body. Do not work in damp area without being extremely careful. Stand on dry rubber mat or dry wood and use insulating gloves when dampness or sweat cannot be avoided. Keep clothing dry.

INSTALLATION AND GROUNDING – Electrical equipment must be installed and maintained in accordance with all the applicable national and local codes.

A power disconnect switch must be located at the equipment. Check the data label for voltage and phase requirements. If only 3-phase power is available, connect single-phase equipment to **ONLY TWO WIRES** of the 3-phase line.

DO NOT CONNECT the equipment grounding conductor to the third live wire of the 3-phase line as this makes the equipment frame electrically HOT, which can cause a fatal shock.

If a grounding conductor is part of the power supply cable, be sure to connect it to a properly grounded switch box or building ground. If not part of the supply cable, use a separate grounding conductor. Don't remove a ground prong from any plug. Use correct mating receptacles. Check ground for electrical continuity before using equipment.

The grounding conductor must be of a size equal to or larger than the size recommended by Code or this manual.

CHARGING LEADS – Inspect leads often for damage to the insulation. Replace or repair cracked or worn leads immediately. Use leads having sufficient capacity to carry the operating current without overheating.

BATTERY TERMINALS – Do not touch battery terminals while equipment is operating.

SERVICE AND MAINTENANCE – Shut OFF all power at the disconnect switch or line breaker BEFORE inspecting, adjusting, or servicing the equipment. Lock switch OPEN (or remove line fuses) so that the power cannot be turned ON accidentally.

Disconnect power to equipment if it is to be left unattended or out of service.

Disconnect battery from charger.

Measure voltage on capacitors and, if there is any voltage reading, wait 5 minutes before to proceed.

Keep inside parts clean and dry. Dirt and/or moisture can cause insulation failure. This failure can result in high voltage at the charger output.

BURN AND BODILY INJURY PREVENTION

The battery produces very high currents when short circuited, and will burn the skin severely if in contact with any metal conductor that is carrying this current.

Do not permit rings on fingers to come in contact with battery terminals or the cell connectors on top of the battery.

Battery acid is very corrosive. Always wear correct eye and body protection when near batteries.

FIRE AND EXPLOSION PREVENTION

When batteries are being recharged, they generate hydrogen gas that is explosive in certain concentrations in air (the flammability or explosive limits are 4.1% to 72% hydrogen in air). The spark-retarding vents help slow the rate of release of hydrogen, but the escaping hydrogen may form an explosive atmosphere around the battery if ventilation is poor.

The ventilation system should be designed to provide an adequate amount of fresh air for the number of batteries being charged. This is essential to prevent an explosion.

Always keep sparks, flames, burning cigarettes, and other sources of ignition away from the battery recharging area. Do not break "live" circuits at the terminals of batteries. Do not lay tools or anything that is metallic on top of any battery.

To prevent arcing and burning of the connector contacts, be sure the charger is OFF before connecting or disconnecting the battery. The digital display must be completely OFF.

MEDICAL AND FIRST AID TREATMENT

First aid facilities and a qualified first aid person should be available for each shift for immediate treatment of electrical shock victims.

EMERGENCY FIRST AID: Call physician and ambulance immediately and use First Aid techniques recommended by the American Red Cross.

DANGER: ELECTRICAL SHOCK CAN BE FATAL.

If person is unconscious and electric shock is suspected, do not touch person if he or she is in contact with charging equipment, battery, charging leads, or other live electrical parts. Disconnect power at wall switch and then use First Aid.

Dry wood, wooden broom, and other insulating material can be used to move cables, if necessary, away from person.

IF BREATHING IS DIFFICULT, give oxygen.

IF NOT BREATHING, BEGIN ARTIFICIAL BREATHING, such as mouth-to-mouth.

IF PULSE IS ABSENT, BEGIN ARTIFICIAL CIRCULATION, such as external heart massage.

In case of acid in the eyes, flush very well with clean water and obtain professional medical attention immediately.

EQUIPMENT WARNING LABELS

Inspect all precautionary labels on the equipment.

Order and replace all labels that cannot be easily read.

2. DESCRIPTION

The LOGIK MHF68 has been designed to charge lead-acid motive batteries. This charger converts the AC input to DC, at the proper value to charge the battery.

The operation is completely automatic, and it's managed by a microprocessor based control system, composed by a Main Control Board, installed inside of the charger, and an optional wireless Battery Identification Module (WBM), that is permanently connected to the battery.

The exclusive power conversion system of the Green Charger is based on a new, patented, frequency multiplier circuit. This system offers very high electrical efficiency, near unity power factor and very low output current ripple.

These features determine a very high electrical efficiency of the entire motive power system (Battery + Charger), because all the losses of the charge/discharge cycle are minimized.

The exclusive charging curve of the Green Charger allows to reduce the charging factor to the minimum value, so the duration of the overcharge/gassing phase and the average temperature of the battery are minimized.

The Green Charger is suitable for Conventional and Opportunity charging applications. It's equipped with a built-in Real-Time Clock, which allows the user to program the desired start time of the day, the full charge time window and to schedule the weekly equalize cycles.

The Green Charger is able to monitor its performances and its energy consumption. It provides estimates of the energy savings, in the three fundamental formats:

- ^ Total Energy Saved (kWh)
- ^ Total Reduction of Greenhouse Gas emission (lbs of CO₂)
- ^ Total Saving on Energy Bill (USD)

These information, and all the operating parameters of the charger are shown on the alphanumeric display.

In addition, it's possible to connect the charger to the Fleet Management System DoctorFleet.com, which allows to monitor the complete fleet through a WEB based interface, and to send automatic alarm messages and usage reports by email.

3. INSTALLATION OF CHARGER

Conditions of use:

- ⤴ **Operating /Storage temperature:** 5°C to 45°C
- ⤴ **Relative humidity:** less than 75%

WARNING !

The charger can be installed by qualified personnel only!
To avoid the risk of injuries, the user is not allowed to open the cabinet.
Always refer to qualified electricians for installation and service operations.

WARNING !

To prevent fire or shock hazard, do not expose the charger to rain or moisture.
Do not use the e charger in presence of flammable gas, because it can generate sparks!
Do not install the charger near flammable materials.

WARNING !

To reduce the risk of fire, the charger must be installed on a
floor of non-combustible material.
If this is not possible, a floor plate of at least 1,6mm steel extended
at least 150mm beyond the charger on all sides must be installed.

CAUTION !

Before to install the charger:
Check that the charger input voltage (V) is identical to your AC power supply voltage.
Check that the charger max input power (KVA) is available from your AC power supply.

GROUNDING AND LINE CONNECTION

WARNING !

**The cabinet of the battery charger must be properly grounded to protect personnel against hazard of electrical shock in case of fault on the charger!
The grounding conductor must have a current carrying capacity equal or higher than the current carrying capacity of the AC-input wires.**

CAUTION !

**Allow adequate air circulation to prevent internal heat buildup.
Do not place the unit near materials that may block the ventilation slots.
Do not install the unit near heat sources such as radiators or air ducts, or in a place subject to direct sunlight, excessive dust, mechanical vibration or shock.**

If the charger is to be connected to the AC power supply with a flexible jacketed cable, one having a separate grounding conductor should be used.

If, for any reason, an input cable which does not include a grounding conductor is used, the equipment must be grounded with separate conductor. Minimum size and color coding requirements must be in accordance with any applicable national or local code.

LOCATION - Choose your installation location to:

- Avoid temperature and humidity extremes.
- Minimize moisture and dust.
- Provide adequate air circulation to prevent the buildup of fumes.
- Install on a cement pad minimum 7” above surrounding curbing or walkways for water flood control, see Figure A and Figure B
- Maintain a minimum of 18” of clearance on the sides of the unit for proper ventilation.
- Maintain 36” minimum clearance on Front and Back for servicing as required by local codes.
- Do not install unit where it will be exposed to direct sunlight.

Fig.A

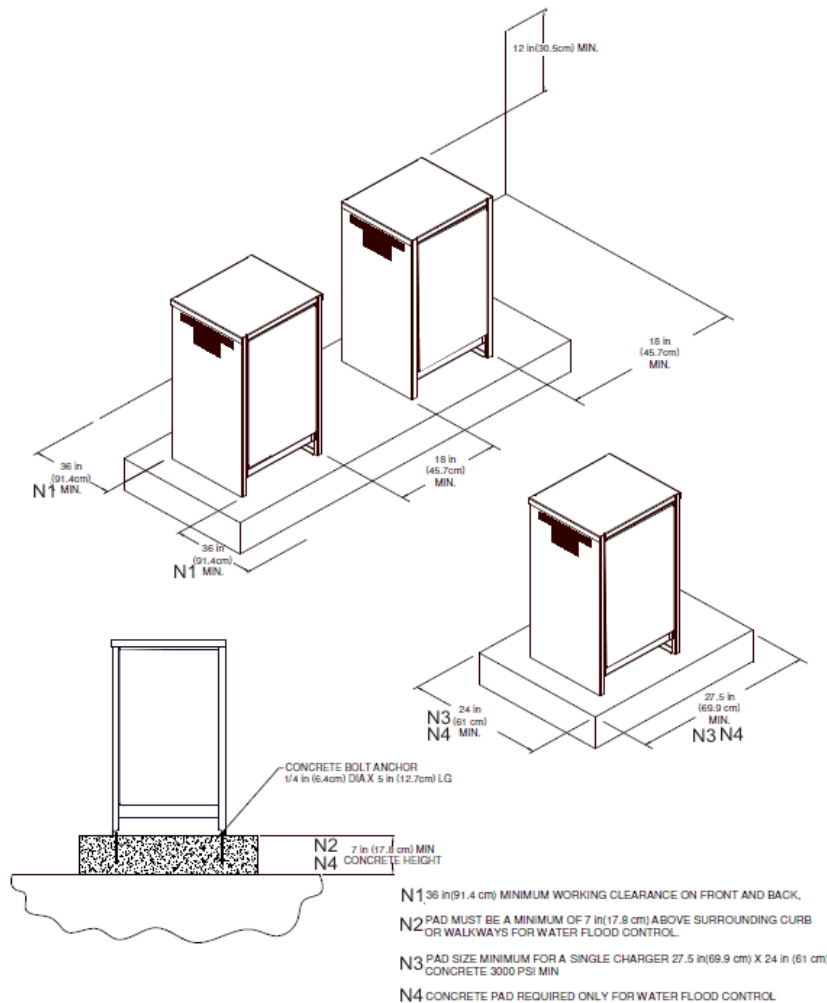
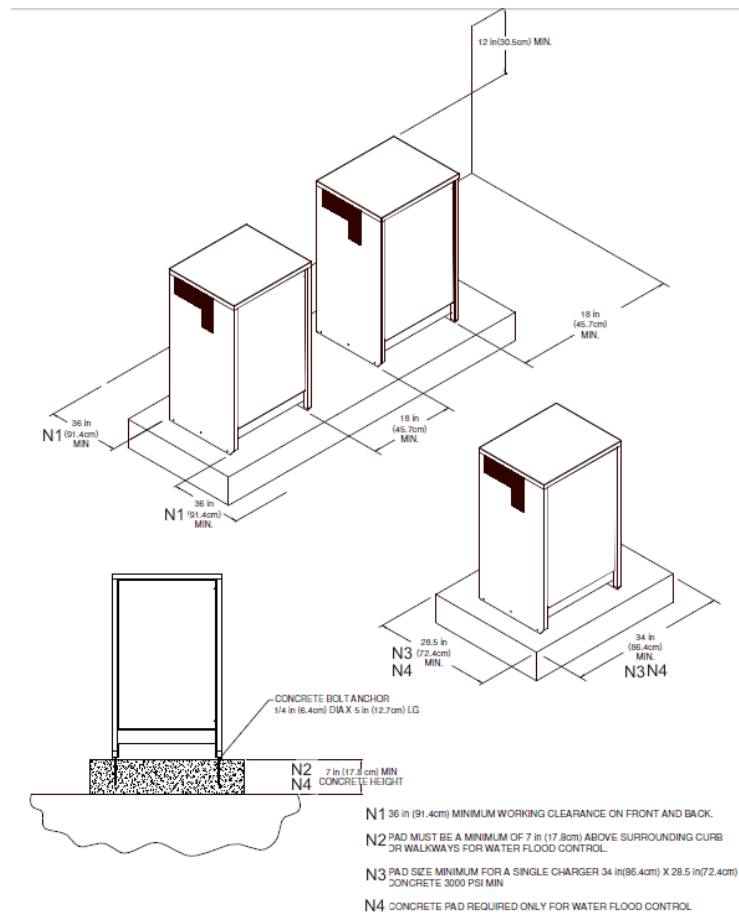

Fig.B



PROCEDURE

- ⤴ **Read on the data label the AC current value corresponding to the line voltage to which charger is to be connected. Using that current value, select the proper fuses, disconnect switch and power cable sizes, according with any applicable national or local code.**
- ⤴ **Check that the charger is disconnected from AC input and battery;**
- ⤴ **Open the cabinet;**
- ⤴ **Mount the input cable and connect the four power conductors (three phase + ground) to the terminal blocks;**
- ⤴ **Close the cabinet;**
- ⤴ **With disconnect switch on AC input power line on position “OFF” or “OPEN”, connect the power cable coming from the charger to the switch and, then, install the fuses in the switch.**

4. HOT USE THE CHARGER



PRELIMINARY CHECKS

- ⤴ Inspect the charger completely for loose screws, electrical connections or other damages;
- ⤴ Check that all the ventilation slots are not obstructed to assure proper air flow;
- ⤴ Make sure that the charger is installed as instructed in this manual and in accordance with any applicable national or local Code.

PROGRAMMATION

Turn on the charger by moving the main switch to position “1”.

The charger will perform an automatic test of the control circuits, and will wait for a random delay on start.

The display will visualize the following messages.

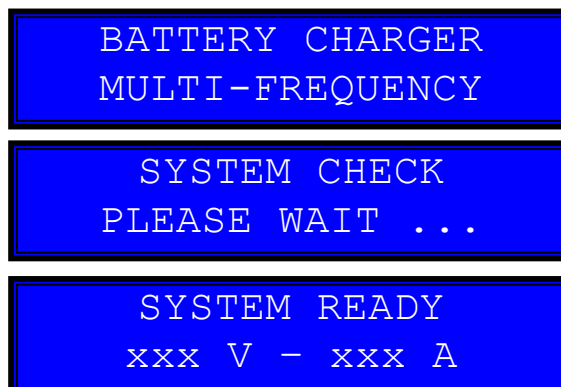

USER PROGRAMMING MODE

HOW TO ACTIVATE USER PROGRAMMING MODE

- ⤴ **Press the button DOWN and keep it pressed for 3 seconds**
The display will show the message:

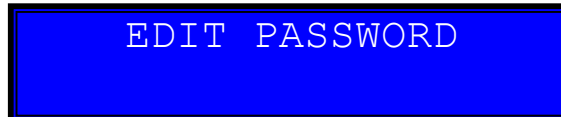

- ⤴ **Enter the Programming Password.**
The display will show the message:



HOW TO MODIFY A VALUE

- ⤴ **Scroll between the programmable values using the UP/DOWN buttons.**
- ⤴ **In order to modify a value, press ENTER and keep it pressed for 2 seconds, until the cursor will start blinking over the value that can be modified.**
- ⤴ **Modify the value using the UP/DOWN buttons.**
- ⤴ **Confirm the modified value by pressing ENTER for 2 seconds, until the cursor will disappear. At this point the new value will be saved.**

HOW TO RETURN TO NORMAL MODE

- ⤴ **Press the buttons UP and DOWN simultaneously.**

PARAMETER 1: GASSING VOLTAGE

GASSING VOLTAGE
 2.40 V/e1

Programmable values: from 2.35 to 2.50 V/Cell

Default value: 2.40 V/cell

NOTES:

This charging algorithm of the Green charger is adaptive, so it's capable of adjusting the charging curve even if the gassing voltage of the battery deviates significantly from the programmed value. For this reason, this parameter should be modified only when using non-standard batteries, or if the operating temperature is extremely low or high. When a battery temperature probe (optional) is connected, the charger compensate the gassing voltage VS temperature of the electrolyte.

PARAMETER 2: MAXIMUM VOLTAGE

MAX. VOLTAGE
 3.00 V/e1

Programmable values: from 2.40 to 3.00 V/Cell, or DISABLED

Default value: 3.00 V/cell

NOTES:

This parameter sets a maximum limit for the cell voltage. If this limit is reached, the charge is terminated and a specific error message is given.

PARAMETER 3: MAXIMUM TEMPERATURE

MAX. TEMPERATURE
 DISABLED

Programmable values: from 35C to 70C, or DISABLED

Default value: DISABLED

NOTES:

Only in use when a temperature probe is connected to the charger of used with a BMOD-T.

PARAMETER 4: EQUALIZE DURATION

EQUAL. DURATION
6 hours

Programmable values: 1-8 hours

Default value: 6

NOTES:

This parameter allows to adjust the total time of EQ.

IMPORTANT:

The EQ is pulsed, to control the level of pulsing refer to parameter 12.

PARAMETER 5: WATERING CYCLE

WATERING CYCLE
DISABLED

Programmable values: 1 to 59 minutes, or DISABLED

Default value: DISABLED

NOTES:

This parameter allows to adjust the total time of REL2 closure for AUTOMATIC WATERING.

IMPORTANT:

The parameter should be adjusted based on the speed of the watering system.

PARAMETER 6: DATE and TIME

MM/JJ/AN hh:mm
01/10/11 10:15

Programmable values: Day/Month/Year, Hour/Minute

Default value: Eastern Time (GMT-5)

NOTES:

It's fundamental to keep the Real Time Clock set to the correct date and time, in order to use all the time base functions. The Charger calculates the Day of the Week automatically.

PARAMETER 7: TIMEZONE DAYLIGHT

```
MM/JJ/AN hh:mm  
01/10/11 10:15
```

Programmable values: USA-MEX-CAN, EUROPE, AUSTRALIA
Default value: DISABLED

NOTES:

When this parameter is well set it's not necessary to adjust the Clock manually in Daylight saving time periods.

PARAMETER 8: START TIME WINDOW

```
START BEG<->END  
00:00 23:59
```

Programmable values: From 00.00 to 23:59
Default value: From 00.00 to 23:59

NOTES:

This parameter sets a time window during the day in which the charger is allowed to start a new charge cycle. If a battery is connected outside of this time window, the charger will remain in stand-by mode until the programmed Start time will be reached. Once the charge cycle has begun, this time window is not considered anymore.

PARAMETER 9: FULLCHARGE / OVERCHARGE TIME WINDOW

```
FULL.CH BEG<>END  
00:00 23:59
```

Programmable values: From 00.00 to 23:59
Default value: From 00.00 to 23:59

NOTES:

This parameter sets a time window during the day in which the charger is **allowed** to fully charge the battery.

Usually, this parameter is used in opportunity charging applications, with the purpose of avoiding useless gassing of the battery during the opportunity charging cycles, and to program a daily full charge of the battery.

PARAMETER 10 and 11: EQUALIZE TIME WINDOW

```
EQ BEGIN TIME
SAT 20:00
```

```
EQ END TIME
SUN 12:00
```

Programmable values: Any day, from 00.00 to 23:59
Default value: From SATURDAY at 12.00 to SUNDAY at 22.00

NOTES:

These parameters set a time window during the week in which the charger is allowed to fully charge and Equalize the battery.

It's recommended to set a minimum Equalize time of 12 hours after the normal completion of the charge cycle.

PARAMETER 12: PULSE RATE EQ

```
PULSE RATE EQ
50%
```

Programmable values: from 1 to 100%
Default value: 50%

NOTES:

This parameter is to set the **rate of the pulsed EQ**. It is based on a repetitive sequence of 10 minutes. The EQ rate represents the percentage of change during this repetitive sequence.

So if PUSLE RATE EQ is 60%, during the EQ the charger will charge 6 minutes and pause for 4 minutes, than restart this sequence for all **EQ DURATION**.

PARAMETER 13: kWh ENERGY SAVING

```
kWh ENERGY SAV.
0.00 kWh
```

Programmable values: Not programmable. Can only be reset by the user.
Default value: Zero.

NOTES:

This parameter represents the TOTAL estimated energy saving achieved by the Green charger, starting from the last reset.

This parameter can be used exclusively to RESET this counter to ZERO.

PARAMETER 14: LANGUAGE

LANGUAGE
ENGLISH

Programmable values: FRANCAIS, ENGLISH, ITALIAN
Default value: ENGLISH

PARAMETER 15: BATT ID. MODULE

BATT. ID MODULE
INACTIVE

Programmable values: ENABLED, AUTOMATIC, DISABLED
Default value: DISABLED

NOTES:

DISABLED -> Don't look for a battery module, start charge right away.

AUTOMATIC -> Look for a battery module, will start anyway if battery module is not found.

ENABLED -> Look for a battery module, will start **ONLY** if found.

IMPORTANT: To **ENABLE** wireless battery temperature with **BMOD-T** you need to access **MAN** parameter and set parameter 16-17.

5. OPERATION

CONNECTION OF THE BATTERY, AUTOMATIC START

Connect the Battery to the charger, using a connector of adequate size.

When the battery is correctly connected, the charger visualizes the following message:



BATTERY
CONNECTED

WIRELESS CONNECTION TO BATTERY IDENTIFICATION MODULE (OPTIONAL)

If the Battery Identification Module is enabled, a few seconds after the connection of the battery, the charger will try to establish a wireless connection. And the display will visualize the message:



BATT ID MODULE
SEARCHING . . .

When the wireless connection is active the charger is ready to start the charging cycle. The display visualizes the message:



BATT ID MODULE
CONNECTED

At this point, the battery information are transferred to the charger and are visualized on the display.

The charger is now ready to start.

Depending on the programmed start time window (Parameter 8), the charger may enter in stand-by mode, and the display visualizes the message:



DELAYED START
(hh.mm)A → (hh.mm)B

Where (hh.mm)A represents the real time at that moment, and (hh.mm)B represents the programmed start time.

When the charge begins, the display visualizes the message:



BATTERY VOLTAGE TOO HIGH

If the battery voltage is higher than a maximum threshold, the charge will not start and the display visualizes the message:



If this message appears, it's recommended to verify that the nominal battery voltage matches the nominal voltage of the charger. Probably a wrong battery has been connected.

BATTERY VOLTAGE TOO LOW

If the battery voltage is lower than a minimum threshold, the charge will not start and the display visualizes the message:



If this message appears, it's recommended to verify that the nominal battery voltage matches the nominal voltage of the charger. Probably a wrong battery has been connected.

It's also possible that the battery has been deeply discharged, bringing the voltage below the minimum value required for the automatic start the charge.

In this case, it's possible to start the charge manually, by pushing the button DOWN for 5 seconds.

CHARGE CYCLE

When the preliminary controls are complete, the charge starts automatically, and the display visualizes the following information:

▲ Battery Voltage	[Volt]
▲ Charging Current	[Amps]
▲ Time of Charge	[hours.minutes]
▲ Capacity Returned	[Ah]

```

xx.x V      xxx A
xxx Ah      x.x t
    
```

The Green Charger performs an exclusive charge cycle that is composed by stages at constant current and stages at pulsed current, with cool down pauses in between. The management of the charging curve is totally automatic.

Depending on the programming of the Full Charge time window (Parameter 9), when the battery approaches the gassing voltage the charger may suspend the charge (typical opportunity charge cycle). In this situation, the display visualizes the message:

```

DELAYED OVERCH.
(hh.mm) A → (hh.mm) B
    
```

Where (hh.mm)A represents the real time at that moment, and (hh.mm)B represents the beginning of the Full Charge / Overcharge time window.

During the cool down pauses, that are normally inserted during the gassing phase, the display visualizes the message “Cooling”.

```

xx.x V      Cooling
xxx Ah      x.x t
    
```

EMERGENCY STOP

If the battery doesn't reach the gassing voltage within a predetermined time, the charger will suspend the charge, and it will visualize the message



EMERGENCY STOP
VGAS NOT REACHED

In this case, the charge cannot proceed, and it's necessary to disconnect the battery. It's recommended to control the battery for damaged cells.

AC INPUT BLACK OUT

If there is a black-out of the AC input, while the charge is in progress, the charger will shut down, while the charge parameters will remain in memory.

When the AC input will be recovered, the charger will restart the charge cycle automatically, and the display will show the message:



RESTART AFTER
POWER SUPPLY OFF

OVERCURRENT PROTECTION

If the AC input voltage is abnormally high and/or the AC input adjustments have not been done correctly (See Chapter “INSTALLATION”), the charging current may reach an excessive value.

In this case, the charger will suspend the charge, and the display will visualize the message:



CURRENT
TOO HIGH

The charge will not proceed, and it's necessary to disconnect the battery. It's recommended to control the AC input connections of the charger, as explained in Chapter 3 “INSTALLATION”.

It's recommended to verify the condition of the battery, as it may have one or more cells in short circuit.

EQUALIZE CYCLE – AUTOMATIC (clock mode)

At the end of the charge, if the battery is left connected to the charger for a sufficient time, the charger activates the Equalize cycle automatically, based upon the programmed schedule.

If the charge cycle ends outside of the programmed Equalize time window, the charger remains in stand-by mode, and the display shows the message:



DELAYED EQUALIZE
DAY TIME

Where DAY and TIME represent the beginning of the programmed Equalize time window.

EQUALIZE CYCLE – MANUAL

During the charging of the battery the operator press button ENTER few secs, and he can force a EQ manual cycle at the end of this cycle.



FORCE MANAUL EQ
ENABLED



FORCE MANAUL EQ
DISABLE

DESULFATION

The operator can every time interrupt the standard charging and enable with a easy procedure a special desulfation cycle. During the charging the operator can scroll the menu in the display with button UP/DW to find:



DESULFATION
toENABL.PrssENTER

In this page press Enter few seconds and the display shows a desulfation menu, in this menu the operator can select the time during of desulfation and the type of restart of desulfation, infact sometimes it is strategic important to complete a standard charging after a completed desulfation cycle.

REFRESH-MAINTENANCE

This function is useful to keep the battery in perfect condition when it's not used for an long period (weeks, months, ...).

It is sufficient to leave the battery connected to the charger. After a normal termination of the charge and the equalize cycle, the control board will activate the charger automatically for 15 minutes of refresh charge every day.

While the charger waits before to activate a Refresh cycle, the display shows the messages:



- ^ Battery Voltage [Volt]
- ^ Nr of Refresh cycles already given to the battery
- ^ Total Time of Charge [hours.minutes]
- ^ Total Capacity Returned [Ah]

During cycle Refresh, the display shows the same set of information that are visualized during the normal charge cycle.

DISCONNECTION OF THE BATTERY DURING THE CHARGE

WARNING !

**DON'T disconnect the battery from the charger while it is being charged.
ARCING AND BURNING OF CONNECTORS OR BATTERY EXPLOSION MAY RESULT!**

If it's necessary to disconnect the battery while it's being charged, press the button UP for five seconds, in order to stop the charger manually.

The charger will suspend the charge and the display will show the message:



At this time it's possible to disconnect the battery.

Eventually, the charge can be restarted, by pressing the button UP for 5 seconds.

6. ENERGY METERING AND HISTORY LOG

The GREEN CHARGER is able to estimate the energy saving during the operation.

While a charge cycle is in progress, the display shows the results relative to that cycle. When the unit is in stand-by mode (battery absent), the display shows the total values.

It's sufficient to push the buttons UP and DOWN, in order to visualize the following data:

^	Energy Saving	[kWh]
^	CO2 Reduction	[lb of CO2]
^	Economic Saving	[USD]
^	Average Power Factor[%]	
^	Average Efficiency	[%]

These data can be reset in User Programming Mode. Please refer to Chapter 4.

The internal memory of the GREEN CHARGER contains a log of the last 200 charge cycles. More than 50 parameters are saved for every charge cycle.

The most significant parameters of the 50 most recent cycles can be visualized on the display of the charger, while the complete history log can be accessed and downloaded through DoctorFleet.com management system.

In order to visualize the 50 most recent cycles, it's sufficient to scroll the menu using the UP-DOWN buttons, and to press ENTER for 3 seconds in order to access the database.

The results of each charge cycle are represented on two pages. Use the UP-DOWN buttons to scroll between each record.

First page:

```
No      VSTART  VSTOP
Date and Time
```

Where:

No = Number of cycle (1 is the most recent)
Vstart = Battery Voltage at the connection
Vstop = Battery Voltage at the end of the charge
Date and Time = Date and Time of the BEGINNING of the charge

Second page:

```
Date and Time
ENDCODE Duration Ah
```

Where:

Date and Time = Date and Time of the END of the charge
ENDCODE = Charge termination code (30 different codes identify all the possible situations that determined the termination of the charging cycle, see next paragraph).
Duration = Total charging time
Ah = Total capacity returned to the battery

7. CHARGE TERMINATION CODES

GROUP 1:**CHARGE COMPLETED**

01

Charge completed successfully.

02

Charge completed successfully.

Equalize NOT executed because battery was disconnected.

03

Charge completed successfully.

Equalize started but not completed, because battery was disconnected during the cool-down time before the Equalize cycle.

04

Charge completed successfully.

Equalize started but not completed, because battery was disconnected while the Equalize was in progress.

05

Charge completed successfully. Over range maximum time during pulsed

06

Desulphation cycle completed successfully.

07

Charge completed successfully.

Equalize completed successfully.

Refresh-Cycle NOT executed because battery was disconnected.

08

Charge completed successfully.

Equalize completed successfully.

Refresh-Cycle started but not completed, because battery was disconnected while the Refresh was in progress.

09

Charge completed successfully.

Equalize completed successfully.

Refresh-Cycle completed successfully.

10

Gassing voltage reached successfully.

Full charge NOT executed because time window Disabled.

12

Charge completed successfully.

Equalize completed successfully.

GROUP 2: MANUAL STOP

11
Charge stopped manually, during a generic cooling state

20
Charge stopped manually, before to reach the gassing voltage.

21
Charge stopped manually, during the finishing charge.

22
Charge stopped manually, during eq.

23
Charge stopped manually, during refresh.

24
Charge stopped manually, during desulphation.

GROUP 3: BATTERY DISCONNECTED

30
The battery has been disconnected before the begin of the charge, while the charger was waiting for the programmed Start Time window.

31
The battery has been disconnected during the first part of the charge, before to reach the gassing voltage.

32
Successful Opportunity charging cycle.
The battery reached the gassing point, the charger entered in stand-by mode waiting for the Full Charge/Overcharge time window, and at that point the battery has been disconnected.

33
The battery has been disconnected during the finishing charge, while it was cooling between two charging pulses.

34
The battery has been disconnected during the finishing charge, while it was receiving a charging pulse.

36
Charge never started.
The battery has been disconnected while the charger was trying to establish a wireless connection with the Battery Identification Module (WBM).

37

Charge never started.

The battery has been disconnected while the charger was communicating with the Battery Identification Module (WBM).

38

Desulphation cycle NOT completed.

The battery has been immediately disconnected, at the beginning of the Desulphation cycle

39

Desulphation cycle NOT completed.

The battery has been immediately disconnected, before to complete the programming of the Desulphation cycle.

40

Desulphation cycle NOT completed.

The battery has been disconnected while the Desulphation cycle was in progress.

GROUP 4:**EMERGENCY STOP**

60

Emergency Stop!

Maximum voltage limit exceeded during first part of the charge, before to reach the gassing voltage.

61

Emergency Stop!

Maximum voltage exceeded during the finishing charge.

62

Emergency Stop!

Maximum voltage exceeded during the equalize cycle.

63

Emergency Stop!

Gassing voltage not reached within the predetermined time limit.

64

Charge never started.

Battery voltage was too LOW

65

Charge never started.

Battery voltage was too HIGH

66

Emergency Stop!

Maximum Current Limit Exceeded.

67

Emergency Stop!

Maximum voltage exceeded during the refresh cycle.

68

Emergency Stop!

Maximum temperature exceeded before to reach the gassing voltage.

69

Emergency Stop!

Maximum temperature exceeded during the finishing charge.

70

Emergency Stop!

Maximum temperature exceeded during the equalize cycle.

71

Emergency Stop!

Maximum temperature exceeded during the refresh cycle.

72

Emergency Stop!

When a battery is connected, the WBM communicate that the voltage of battery is not compatible with this charger

76

Emergency Stop!

Maximum temperature exceeded during desulphation.

GROUP 5:

WARNING MESSAGES

80

Maximum finishing charge time (safety timer) exceeded.

Charge termination criteria (dV/dt) not reached.

82

The battery has been disconnected while the charge was in progress, in a generic state.

83

Output fuse blown.

85

Communication problem with Wireless Battery Module.

99

Black out of the AC input.

- END OF MANUAL -